

DURAFORM® WORLD HEADQUARTERS



DURAFORM's 44,00 square foot facility in Waunakee, WI is home to our corporate offices and manufacturing facility. DURAFORM® also maintains an east coast office and warehouse and supports a network of distributor/dealers throughout the United States and Canada



DURAFORM® helping to form America since 1957!

All Rights Reserved. ©2009 DURAFORM LTD



DURAFORM®
CONCRETE FORMING SYSTEMS
Since 1957



National Sales:
1-800 FORMING (367-6464)
Eastern Sales:
1-800 243-0168

www.duraform.com

Efficient And Accurate, DURAFORM® Saves Time And Money On Your Residential, Agricultural And Light Commercial Applications.

With the DURAFORM® system, a four man crew can actually do one complete basement per day. By this we mean strip yesterday's wall, set up and pour a new wall, and set and pour a footing for the next day. With experience it can be done even faster.

DURAFORM® Is Complete

There are no parts to lose. A standard 2' x 8' panel weighs about 73 lbs., and has built-in waler bars, hardware and locking latches.

DURAFORM® Is Accurate

Start with a chalk line and steel corner. Then all panels interlock and brace with each other for support, proper alignment and maximum strength. It's that easy.

DURAFORM® Is Versatile

Filler panels come in varying widths from 4" through 24" to create virtually any length of wall specified.

Low Cost Per Pour

Because of DURAFORM's® quality construction there are panels in use with over 300 pours to their credit and are still producing good looking walls. Due to the DURAFORM® design, your tie costs are lower, giving you higher net profits per pour.



Questions? Contact us:

Duraform, Ltd.
301 Raemisch Road. P.O. Box 365
Waunakee, WI 53597
1-800-367-6464
1-608-849-3676 (fax)
www.duraform.com



DURAFORM® helping to form America since 1957!

DURAFORM CONCRETE FORMING SYSTEMS • 1-800-367-6464 • FAX: 1-608-849-3676

www.duraform.com

DURAFORM – Frequently Asked Questions

Do you rent forms?

Yes, we do rent to individuals and businesses in Wisconsin. Credit card and cash sales only. No personal and/or business checks accepted for rentals. Please contact our Corporate Sales Staff at (608) 849-3000 for pricing and availability.

What kind of plywood do you use to manufacture DURAFORM® panels?

DURAFORM® forms are manufactured using plywood that was rated by the American Plywood Engineers as being the optimum configuration for concrete forming applications. Our plywood is 1 1/8" 11 Ply Structural I Douglas Fir with a High Density Overlay.

How do you form angle walls for bay windows, etc?

DURAFORM® manufactures corner sets that allow these angles to be easily poured. We have several options available. Possibilities include 45° inside and 135° outside fixed corners or our 4"x4" hinged corner could be substituted for the 45° inside corner. Also available are 45° outside corner clips, which are used in conjunction with the proper size filters to replace the 135° fixed outside corner.

Why do some of your ties have a crimp or bend?

The DURAFORM® Crimp Tie is designed so it will not spin in the wall when you are stripping. This reduces water leakage in the wall. The crimp in the tie also helps secure the re-bar.

What makes your system superior?

We know our system is superior and this is not just an opinion. Historically, we were the first to manufacture a 1 1/8" forming system with attached hardware. The design was so efficient that very soon there were copies of the DURAFORM® System being manufactured. If it wasn't the best, who would copy it? As a company, we are always looking for any technology to improve our system. Over time we have made changes as necessary including chamfered edges, sealed form edges, improved accessories and most recently the change to a "boron" latch. Our manufacturing standards result in consistent quality, add to that the strongest latch in the industry, as well as the best plywood, and it is a logical conclusion that the DURAFORM® System is superior.

Can I use your forms to pour walls of any thickness?

DURAFORM® manufactures ties in lengths from 4" to 72" and custom longer sizes. Basically, any wall size can be poured using the proper length tie.

What do you use to treat the forms so they will release from the concrete?

We recommend a concrete form release agent such as Duracote. We have

both concentrate and ready-to-use formulas available in 5 gallon and 55 gallon sizes.

What is the advantage of the DURAFORM® Deluxe System over the steel ply form?

The DURAFORM® system is much quicker to put up. All the hardware is attached and you can immediately begin putting forms in place. The DURAFORM® system is also lighter in weight comparison to a steel-ply system.

How high can the Deluxe System be stacked?

Foundations as high as 24' and greater can be accomplished with the Deluxe System, 6-bar spacing. As long as you properly place the right walers and bracing, and watch your rate of pour, the Deluxe System can meet your requirements.

What, if any, are the advantages of the DURAFORM® Deluxe System over an aluminum form system?

The obvious advantage of our system is the cost. An average DURAFORM® set usually costs less than half of the price of an aluminum set. Accessories are also significantly less. The DURAFORM® System is easier to set windows and vents. With the DURAFORM® System, you need only one grade of form release agent over the entire life-span of the form. With aluminum, various grades are required over the life span of the forms.

Must I use a footing strip for your system?

Unlike other form systems, the DURAFORM® Deluxe System does not require a footing strip. Our forms simply "free-float" on the footing, adding to a superior speed advantage. There is no need with a DURAFORM® System for a perfectly level footing.

Who exactly is purchasing the DURAFORM® Deluxe System?

Any foundation contractor or block mason who is looking for a faster, more efficient, and more cost-effective wall forming system.

Why should I purchase a forming system from DURAFORM®?

Since 1957, DURAFORM® has been the leader in innovation and improvements in concrete forming systems. No one else can offer the superior blend of quality products, dependable service, competitive pricing, and people who want to see their customers and their customer's business succeed.

17



DURAFORM® helping to form America since 1957!

DURAFORM CONCRETE FORMING SYSTEMS • 1-800-367-6464 • FAX: 1-608-849-3676

www.duraform.com

Stripping

- 1) After concrete has set, usually the next morning, remove lineup rail, waler planks, brackets, bulkhead nails, and turnbuckle braces.
- 2) Break off tie wire ends with break off tool.
- 3) Release all latches.
- 4) Strip inside forms and lean them against the finished wall.
- 5) Strip outside forms and lean these against the dirt bank. When stripping, tapping the tie slots with a hammer will remove concrete from tie slots and routs.
- 6) The second break back of the ties (normally 1/4" inside the wall line) is done with a hammer. Hit the tie stubs in a horizontal plane. This operation is best done by the owner or builder after the concrete has reached near its ultimate strength. Stubs on outside walls covered with back fill need not be broken off unless local codes require it.

Very Hot Weather

Hot weather is not as great a problem as very cold weather. However, a few simple precautions are necessary to insure quality results:

- 1) Eliminate unsightly "cold joints" by avoiding long delays between loads of concrete.
- 2) Do not use concrete that has been in the mixer too long.
- 3) Do not delay striking off, setting of anchor bolts, etc.
- 4) Wall should be stripped the day after pouring. If forms are left on wall longer, they will be harder to free from the wall.

Very Cold Weather

The minute that ready-mixed concrete is discharged into forms, the responsibility for the concrete and its level of quality is transferred from the producer to the contractor or user. For this reason, under cold weather conditions, the development of high quality walls should be guarded through the use of specific techniques. Freshly placed concrete is vulnerable to freezing temperatures both before and after stiffening occurs. If concrete is permitted

to freeze while it is still plastic, the expansion of water will render it useless. If freezing takes place after stiffening occurs, permanent damage to the concrete may be caused. Strength can be reduced as much as 50%, bond and durability can be reduced and increased porosity can result in scaling and spalling of the hardened concrete surface.

Fortunately, the 1 1/8" thick plywood used with the **DURAFORM®** Deluxe form is an excellent insulator and when the overnight temperatures are above 25°F, no additional protection is needed. When the overnight temperatures go below 25°F, some additional protection is required. This can be done by increasing the cement content of the concrete, by the addition of calcium chloride, heating of the mixing water and concrete aggregates and by covering the forms after pouring. In very severe weather it may be necessary to use all of these.

Basic to the use of concrete in winter is the fact that concrete should never be placed on frozen subgrades. Before placing concrete, all snow, ice and frost should be removed. The inside of forms, reinforcing steel, embedded conduits, window bucks, etc., should be cleared of ice and snow before the concrete is placed.

Keep in mind that the rate of pouring should be reduced in cold weather. The setting time of concrete is directly related to the temperature of the concrete. During warm weather the pressure exerted on the forms is somewhat relieved at the lower part of the forms due to the fact that the first concrete put into the forms has started to harden; whereas, in cold weather it has not and therefore, exerts a much greater pressure on the forms.

Because the concrete itself generates heat by the chemical action involved in the hardening process, the forms can be stripped the following day during periods of moderate temperatures. During periods of continuing low temperatures, it is safer to leave the forms on the wall for a longer period even if they are a little harder to remove.

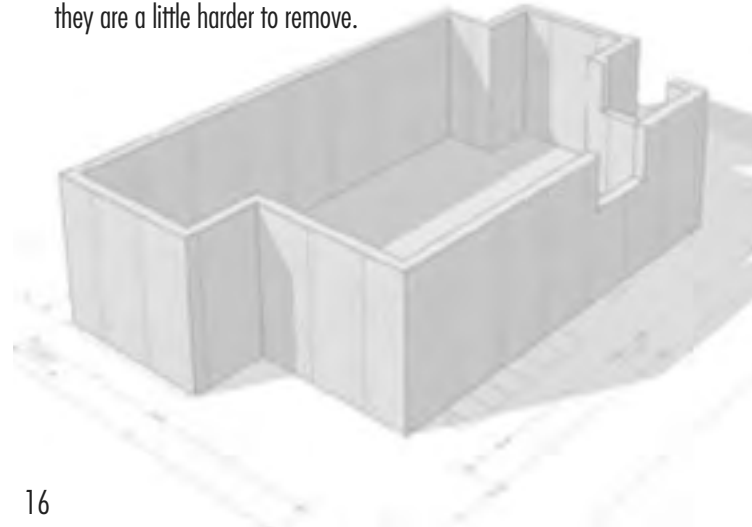

Table of Contents..... Pg 1
 Duraform Concrete Forming System.....Pg 2 & 3
 Duraform Bar Spacing..... Pg 4
 Duraform Latches & Clips..... Pg 5
 Duraform Ties & Corners..... Pg 6
 Duraform Clamps, Strongbacks & Walers Pg 7
 Duraform Brackets, Turnbuckles, Break-off Tools Pg 8
 Duraform Rails, Spreaders & Stacking Plates..... Pg 9
 Duraform Form Sprayers & Chutes Pg 10
 Duraform Laying Out the JobPg 11 & 12
 Duraform Footings, Setting Up Forms, Garage & Pouring.....Pg 13, 14 & 15
 Duraform Stripping Forms & Weather Conditions Pg 16
 Duraform Frequently Asked Questions Pg 17

About the DURAFORM® Company

The **DURAFORM®** brand has always carried the reputation for being the leader in the 1 1/8" concrete forming industry. Founded in 1957, the company has been through ownership and location changes, but the high quality product and services it provides has always remained constant.

DURAFORM, LTD, formerly Medalist Forming Systems, was purchased by Mr. James White in 1992. White, while employed by Medalist, worked his way up to president, but was terminated in 1975. He then did what no one expected. He created a competing company, ACCUFORM, Inc. In 1991, Medalist decided to sell its forming division and Jim White recognized the opportunity to again lead this company. In September 1993 the sale was completed that allowed White to restore the **DURAFORM®** name and refine the historic quality with which the name was synonymous.

Second generation ownership continues this vision. The **DURAFORM®** team remains dedicated to growth through innovation, maintaining the honest and loyal foundation that formed our reputation for excellence.



PRIDE IN OUR PRODUCT... PROUD OF OUR HERITAGE

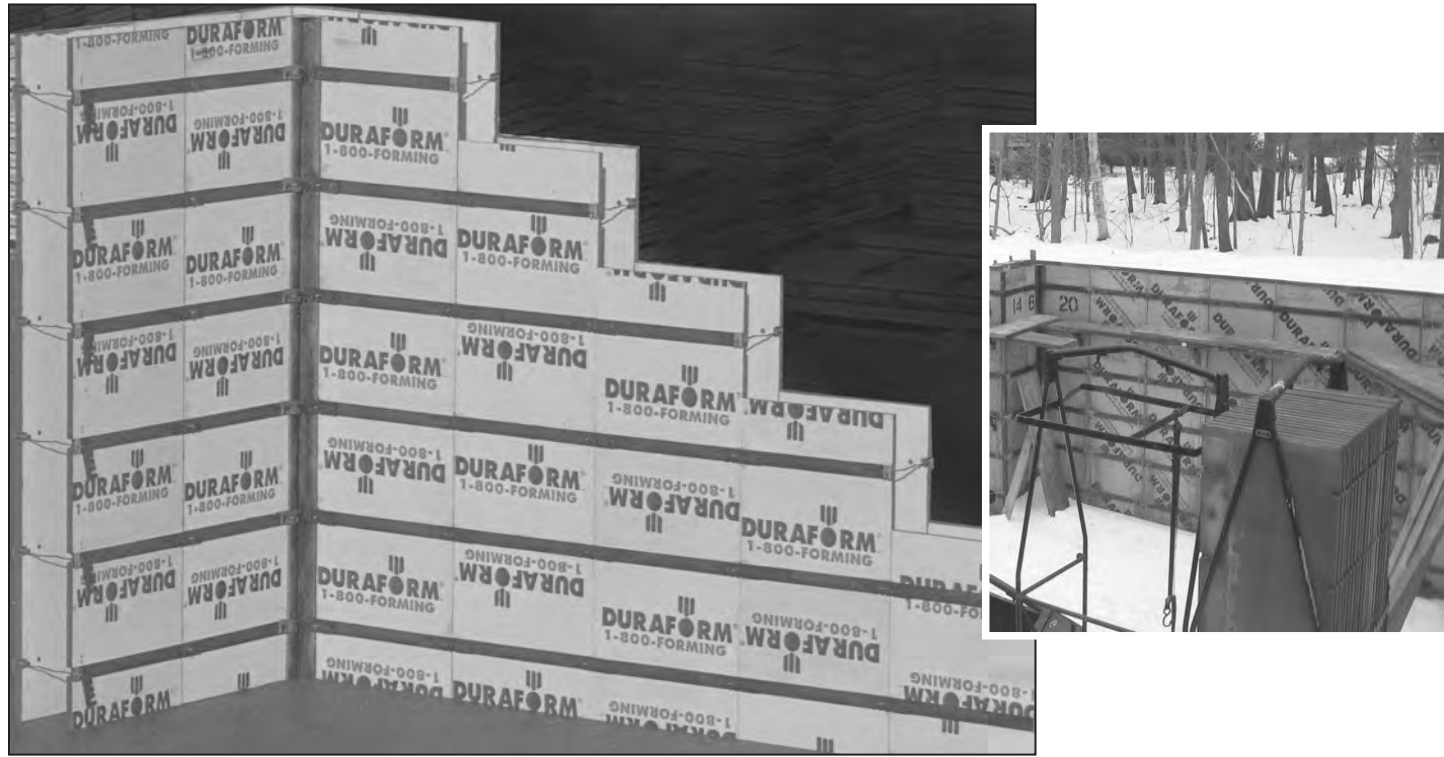

DURAFORM® Concrete Forms

1 1/8", structural 1 grade forming plywood made of 100% Douglas Fir with 11 plys for added strength and durability. DURAFORM® was the first to offer chamfered edges and an improved edge seal. DURAFORM® Concrete forms are efficient and accurate. This saves our customers both time and money!

Available in standard bar spacing options or customized to fit your needs, DURAFORM® Concrete forms will out-perform the competition pour for pour. Deluxe forms are designed to create an economical fast setting residential or commercial system. Each panel is reversible to give complete flexibility for both outside and inside walls. "Four men can set and pour a 44' x 28' basement in approximately 4 hours."

What makes our system superior?

We know our system is superior and this is not just an opinion. Historically, we were the first to manufacture a 1 1/8" forming system with attached hardware. The design was so efficient that very soon there were copies of the DURAFORM® System being manufactured.

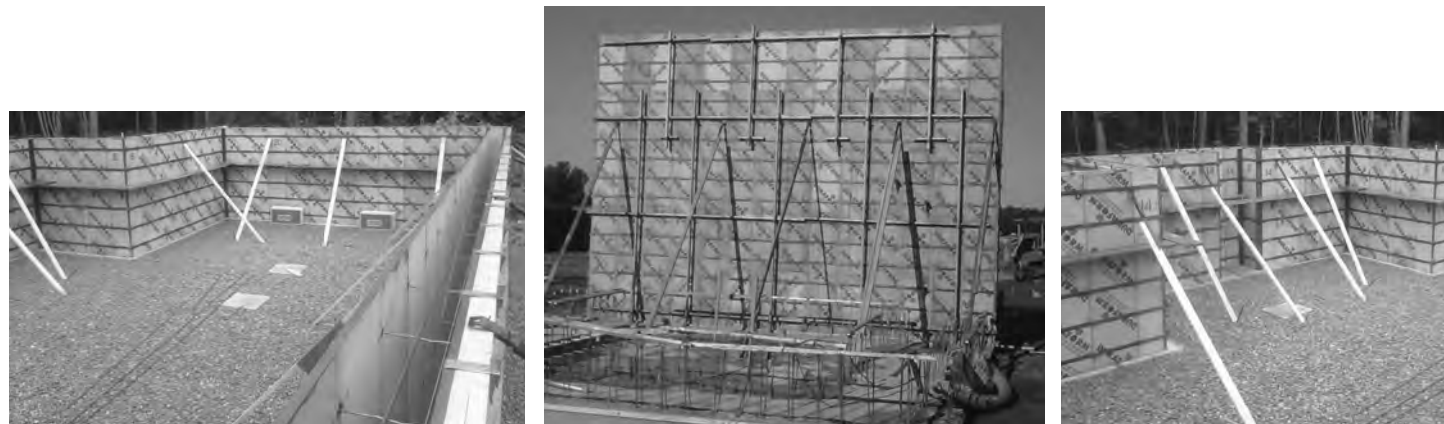

In Forming Basement Wall & Attached Garage

If possible, set garage footing exactly 4' higher than basement footing. The top latch on the 8' form will then match the top latch on the 4' form. With the Deluxe 4-Bar system, the bottom latch on the 4' form will not match a bar on the 8' form. However, if you nail the latch in a horizontal position, with the tie locked in place, the forms will not spread. With either the 5-Bar or 6-Bar system, all bars will match.

Rip 2" stock to the wall thickness (or slightly less) for both the bulkhead and the horizontal bridge. Place vertical bulkhead against the ties to help hold the concrete pressure. Nail securely using scaffold nails (double head). Place ties in slots on 8' form and lock in place with corner clips. On long bridges it is advisable to reinforce with at least two No. 4-Bars across the bridge. Keep X dimension as short as possible.

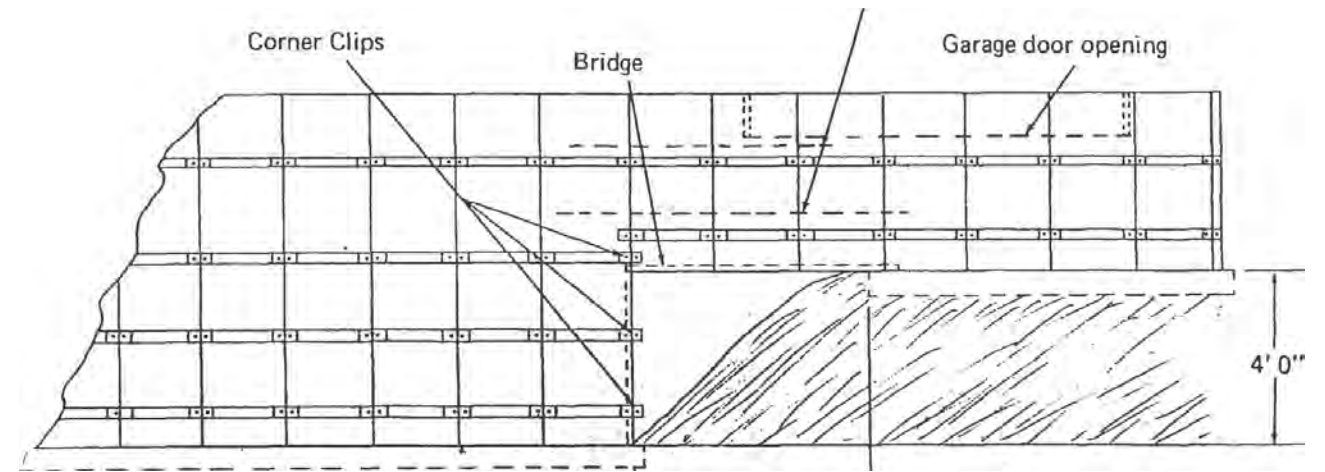

Pouring the Wall

- 1) Before starting to pour, check the following
 - A) Are the forms set so chalked lines show?
 - B) Is foundation square, grades set?
 - C) Are all latches locked and corner clips in place?
 - D) Is line up rail in place? All windows, bulkheads and other inserts nailed safely in proper position?
 - E) Are the forms adequately oiled?
- 2) After the above check, you are ready to pour. Although many Deluxe form users will pour an eight foot high wall in 45 minutes, we do not recommend pouring more than four feet of concrete per hour. Pour at or near the corners. Do not pour directly into an offset. Always use air entrained concrete and pour it quite wet. The pressure exerted on the forms and ties is indirect proportion to the rate of pouring and this is modified by the temperature of the concrete. The higher the temperatures, the faster you can pour and vice versa.

- 3) Fill forms up to grade nails and strike off using thin wood float. Another method of striking off is with a 2" x 4" about five feet long. In this case, put grade nails in level and strike off on top of them. While concrete is still plastic, line up walls. This is best accomplished by nailing a block of wood to the outside of the forms at each corner about three or four inches below the top of the forms. Stretch a mason line between these blocks and use a third block of the same dimension to check the space between the forms and the string. While concrete is still plastic, you can push the top of the forms in or out to line the wall using DURAFORM® turnbuckle or a 2 x 4 brace to hold forms in position until concrete sets.
- 4) Before leaving the job, pick up all loose hardware, tools etc. Clean up concrete spills, particularly where forms sit on footings. Remember—that innocent looking puddle of concrete today will be a king size paperweight tomorrow!

DURAFORM – FOOTINGS/SETTING UP FORMS

- 5) Any fractions needed are best placed near the middle of the length of the run. However, do not attempt to "button up" near the middle of a run. Do it near a corner, as minor misfitting of the last panel can be corrected by moving the corner slightly. The forms can be shifted slightly by means of a waler bracket attached to the bottom bar. Use a 2"x 4" as a lever against the waler bracket.
- 6) After the formwork is "buttoned up", the waler brackets are attached, usually on the outside forms, at the desired level. Place brackets on every form. Place waler planks and oil forms.
- 7) Any windows, doors, bulkheads may be put in at this time. Locate each and if necessary, remove ties that interfere. Set the windows, square and nail in each corner. Replace any ties, make sure all latches are locked. If the corner fractions were not put in, do it now. Install line up rail.
- 8) Using transit, establish grade elevation for the top of the wall. Drive a small nail into the outside forming at the corners. Snap a chalk line between these nails, then drive a small nail into each panel along this line.

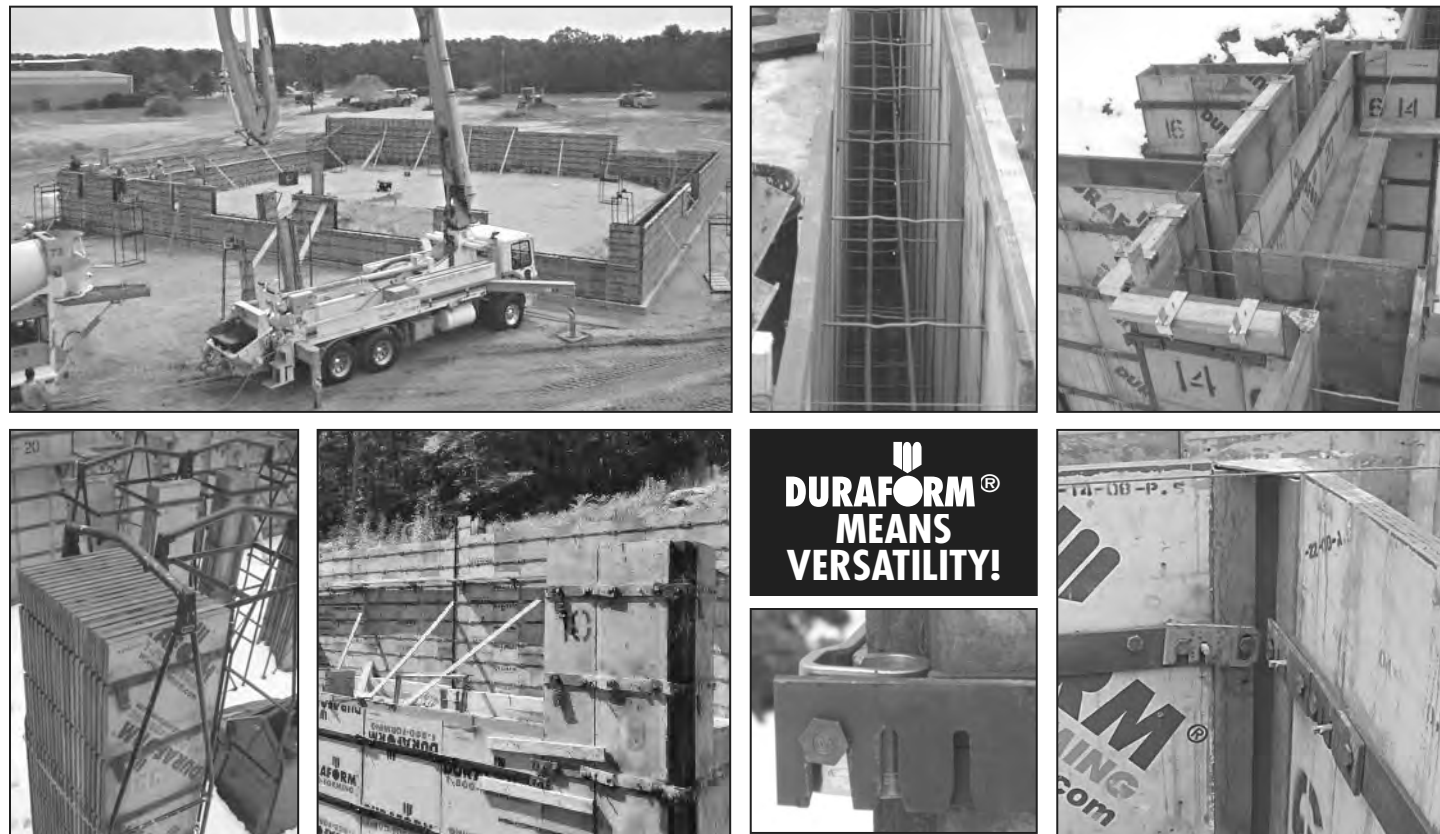

DURAFORM CONCRETE FORMING SYSTEM

DURAFORM®

If it wasn't the best, who would copy it? As a company, we are always looking for any technology to improve our system. Over time we have made changes as necessary including chamfered edges, sealed form edges, improved accessories and most recently the change to a "boron" latch. Our manufacturing standards result in consistent quality—led to that the strongest latch in the industry, as well as the best plywood, and it is a logical conclusion that the **DURAFORM®** System is superior.

2' Stacking panels are used when additional height is required above a **DURAFORM®** Panel. Example: 10' walls are achieved by using our 8' form, with a 2' stacker panel, 6' walls are achieved by using our 4' form with a 2' stacker panel. Stacking panels are set best when vertical 2'x4's are placed on either or both sides of the wall. Strongback clamps are recommended for this application.

DURAFORM® Identification of Parts

The following pages will be an aid to ordering. Many construction items are called by various names. Use of the official names shown will help to keep your order accurate.

Deluxe forms are designed to create an economical fast setting residential or commercial system. Each panel is reversible to give complete flexibility for both outside and inside walls. "Four men can set and pour a 44' x 28' basement in approximately 4 hours."

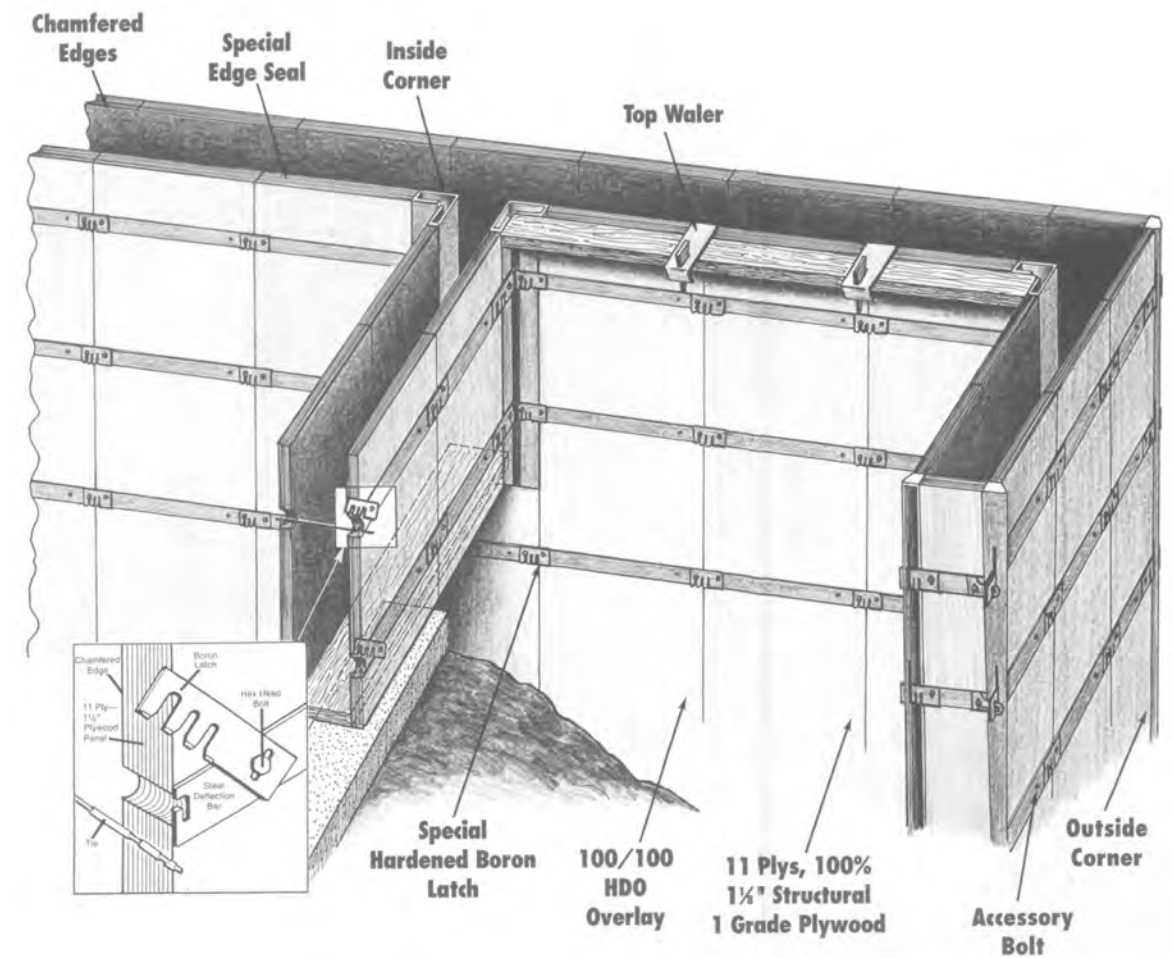

Standard Panel Sizes and Specifications

DURAFORM® Deluxe 4 Bar Concrete Form

Technical Information: Panels are constructed of 1 1/8" plywood (11 ply 100/100 HDO). Four steel deflection bars with attached locking system for speed in erection. Weight is approximately 72 lbs. per 2' x 8' panel.

DURAFORM® Deluxe 6 Bar Concrete Form

Technical Information: Panels are constructed of 1 1/8" plywood (11 ply 100/100 HDO). Six steel deflection bars with attached locking system speeds erection. Weight is approximately 83 lbs. per 2' x 8' panel. Panels can be stacked by alternating various size forms.

DURAFORM® Deluxe 5 Bar Concrete Form

Technical Information: Same as other Deluxe panels. Has advantage of less deflection than four bar form. Weight is approximately 75 lbs per 2' x 8' panel.

A 2' x 2' panel is available for use with 10', 8', 6' and 4' panels to provide flexibility in height. Also, filler widths of 4" through 23" are available.

For projects which require wall heights taller than 8', our factory can produce forms at 8'6", 9', 9'4" and even 10'. We can custom fit the deflection bars to match any shorter form waler bar spacing.

Need something special? Give us a call!

CHOOSE FROM 3 DELUXE SYSTEMS Waler Bar Spacing—Center To Center

8' 4 Bar System	8' 5 Bar System	8' 6 Bar System
20"	20"	8"
24"	20"	16"
24"	18"	16"
20"	16"	16"
8"	14"	16"
	8"	8"

Panels, fillers & corners are also available in the following heights: 10', 9'4", 9', 8'6", 6'8", 6', 5'4", 5', 4', 2'8" and 2'

DURAFORM® 6 BAR SPACING SYSTEM

				120"	16"
			96"		16"
					16"
		64"			16"
	48"				16"
32"					16"
					8"
2'8"	4'	5'4"	8'	9'4"	10'
2 BAR	3 BAR	4 BAR	6 BAR	7 BAR	7 BAR

Installing the Footings

In many parts of the country, local building codes allow footings to be "trenched". If this can be done in your area, great savings can be realized with this method. The footing trenches are dug with a hand shovel and the material removed from the trenches is put alongside the trench. After the trenches are dug, the grade elevation of the top of the footings is set using a transit. Grade stakes made of 3/4" x 3/4" wood stakes are driven into the ground in the center of the trench about 12 — 14 feet apart. The concrete is poured into the trenches and roughly leveled with hand shovels. The concrete can then be easily leveled using a 2 x 4 strike off placed on top of the grade stakes. Minor high and low spots are no problem, as the Deluxe Panels will "ride" with these imperfections and still lock up.

Post footings are done in the same way, at the same time the wall footings are poured. Most footings can be reached for pouring by use of one DURAFORM® concrete chute plus the mixer chutes.

After the concrete has set, usually the next day, the footings are marked for form setting using a chalk line. It is a matter of personal preference which side of the wall is chalked.

Setting the Forms

1) To begin the setting operation, start at the corners and work in both directions. Set inside corner and one "regular" each way on inside forming. Place tie wires in the tie slots. Make sure flat of tie is horizontal. Set regulars on outside forming opposite the regulars previously set on inside forming, threading ties through corresponding tie slots in outside forms. The outside fractions may be placed now or left until all walls are set.

You will notice that the latches are attached to the forms on the left side. This means that on the inside forming, at the corner, the regular form to the right of the corner will have a latch attached to the form at the inside corner and the regular form to the left of the inside corner will not. This is where the loose or unattached corner clip is used.

2) Before engaging the latches over the tie wires, use a level to check edges of forms for plumbness on both inside and outside forming. It may be necessary to shim one or both starter panels to plumb them. Once plumb, all latches should be engaged. Check the succeeding 2 or 3 panels for plumbness. Also check to see that the inside and outside panels are set squarely opposite one another. (Tie wires 90° to inside face of panel.)

3) Always keep the chalked line on the footing visible as form setting continues. Repeat the corner plumbing operation as each corner is turned.

4) After about ten or twelve lineal feet of wall has been set, it is best to attach a sidewall brace for protection against the wind. Typically a brace every 20 feet (approximately) is sufficient. The DURAFORM® turnbuckle sidewall brace should be adjusted so the forming is plumb at each brace. Don't worry if the top of the forming is not straight at this time.



Bow or Bay Window Forming

Using Fixed or Hinged Special Corners
4" x 4" Fixed or Hinged Inside Corner

Fixed or Hinged 135 Degree Outside Corners

7 5/16" X 7 5/16" For 8" Wall
8 1/8" X 8 1/8" For 10" Wall
7 3/4" x 7 3/4" Has Been Ordered For Either 8" or 10" Wall
9" x 9" For 12" Wall

Use 90° Inside Corner Pieces for 45° Fixed inside corners or 135° Fixed Outside Corners.

For outside hinged corner, use appropriate hinged corner piece and add the difference between 4" x 4" standard inside corner and 8" x 8" standard inside corner.

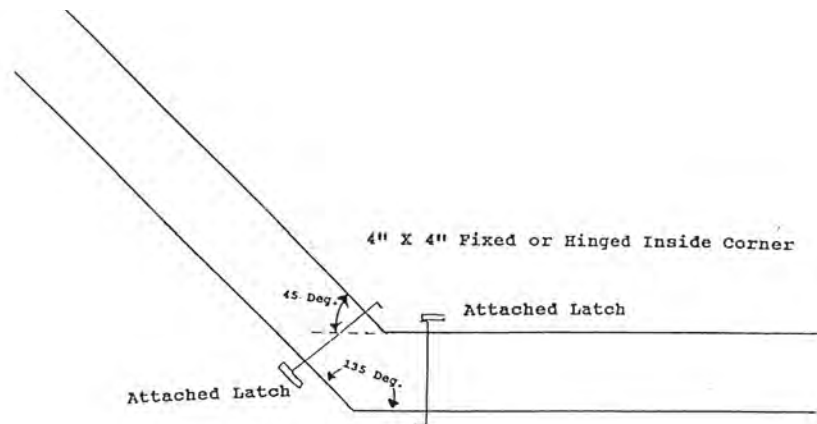

FRACTIONS NEEDED AT A "TEE"

The fractions required on the outside of the main wall are determined by taking the cross-wall thickness and adding the sum of the inside corner dimensions.

Wall Thickness will change at the TEE

Many plans call for a wall thickness change. These changes usually occur at a tee, and usually the change is by 2". DURAFORM® inside corners are made simple. By using different combinations of inside corners and fractions, practically any situation can be handled. If you are in doubt, the best way is to make a sketch. Keep in mind that ties must always be 90° to the wall.

BULKHEADS

This is the most common method for forming stoop walls as nothing special is required. The corners and panels may be used anywhere in the wall. Naturally, a special stoop panel has only one specific purpose.

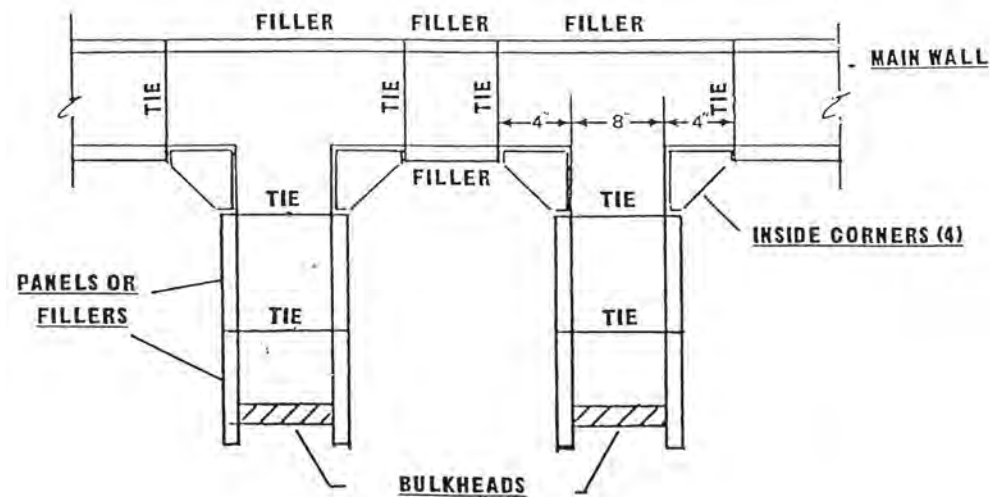

Panel Latch

Used to secure DURAFORM® panels together or to secure panels to corners in the desired configuration.

- DURAFORM® Boron Panel Latch is one of the hardest latches manufactured, insuring strength and durability.

Half Clip

- Constructed of hardened steel, half clips have a single tie slot to secure tie position when the attached latch hardware cannot be used.

Corner Clip

- Constructed of hardened steel, these clips are used to attach 4" and 5" filler panels to adjacent full size panels or fillers.

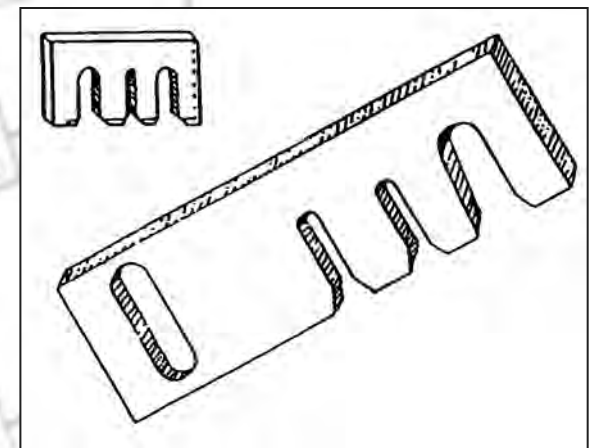
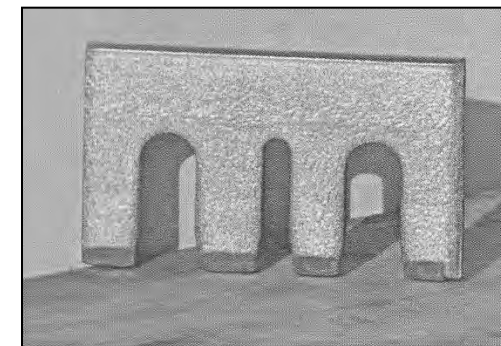
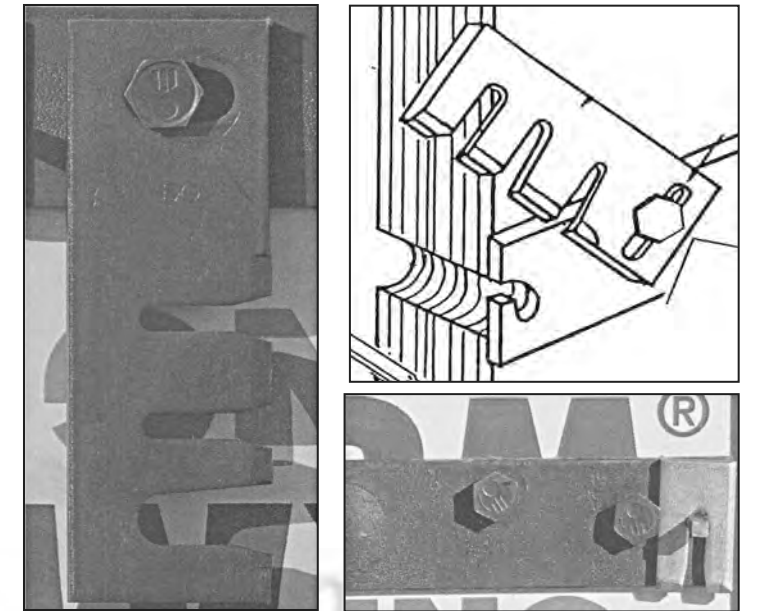

Deluxe Ties

Used to secure DURAFORM® panels together in the desired width.

- DURAFORM® has one of the hardest ties manufactured, insuring strength and durability.

DURAFORM – FORM TIES

- Crimp design reduces leakage.
- Breakback design assures a burr free break for ease when stripping forms.
- Detent to improve the mechanical lock with concrete, securing the tie and reducing the chance for water infiltration.

Also available in Economy style. Economy style features the same high grade product, with a straight profile design for ease in tie placement. This product offers the same breakback design for burr free ease in stripping forms, as well as the detent to improve the mechanical lock with concrete to secure the tie.

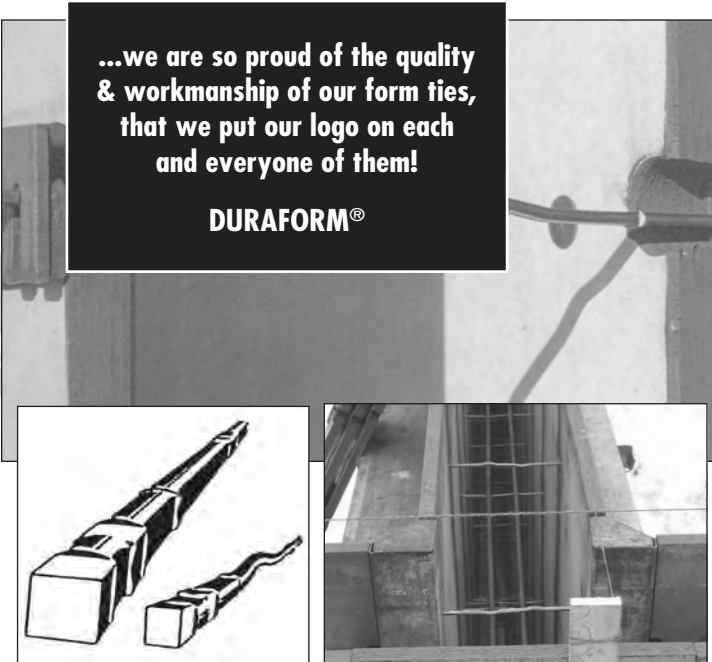

DURAFORM - CORNERS

Available in both inside and outside styles, and multiple configurations, the DURAFORM® corners provide the security and stability to assure a quality pour on any job!

Inside Corner

- Strong, 10 Gauge steel.
- Rugged, additional bends add extra strength.
- Field repair capability - no more running back to the shop to weld or repair latches! Just a hex bolt and hex nut or a new latch and you are back in business with no time wasted.
- Attached hardware speeds set up and break down - saving time and money.
- Punched for all standard bar spacings.

Outside Corner

- Strong, 10 Gauge steel "J" formed design.
- Eliminates need for corner clips.
- Latches are attached and can be replaced in the field.
- Available in all height/bar spacing configurations.
- Available in both "J" corner and tube corner configurations.

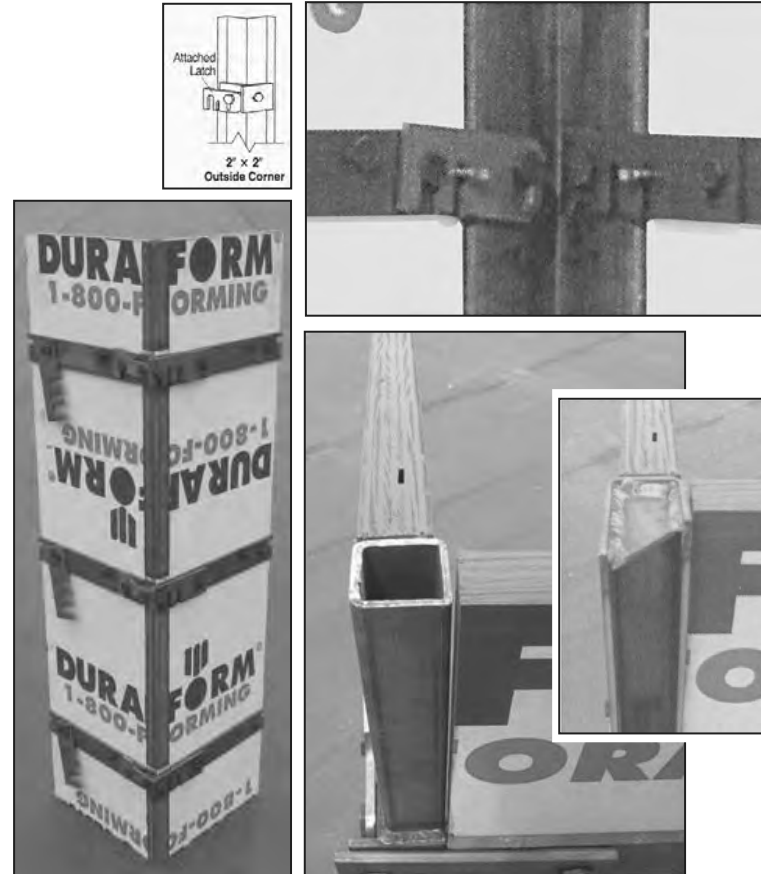

6

DURAFORM – LAYING OUT THE JOB

By all means — determine in advance the number of panels, fractions, tie wires and accessories required for the job. A simple layout will streamline the job, and the savings in the field will be more than worthwhile.

The fact that steel backing bars abut each other in the DURAFORM® system makes it possible to create an advanced layout. There is no "growth" and very exact dimensions are maintained.

OUTSIDE FRACTIONS NEEDED AT A CORNER

The rule here is:

Wall thickness + inside corner dimension = outside fractions required

For example, you are pouring a 12" wall and you are using 4" x 4" inside corners. You will need a pair of 16" fractions on the outside.

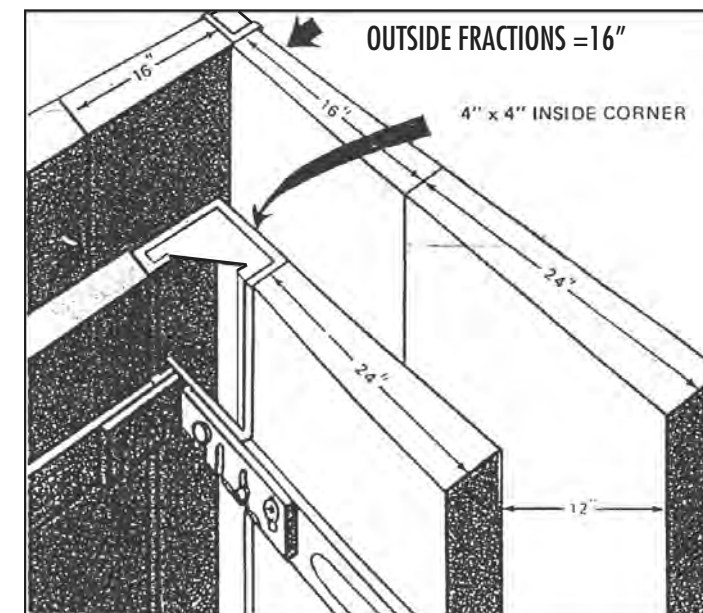

8" Walls with lengths of even numbered feet and no inches require no fractions in the run. If there are also inches in the dimension, the inches are the fraction size.

Number	Size	
_____	_____	Regulars
_____	_____	Fractions for corners
_____	_____	Fractions for walls
_____	_____	4" x 4" Inside corners
_____	_____	Outside corners

12" Walls with lengths of odd numbered feet and no inches always require 12" fractions in the run. If there are also inches in the dimension, add them to the 12" to get the fraction size needed.

Number	Size	
_____	_____	Regulars
_____	_____	Fractions for corners
_____	_____	Fractions for walls
_____	_____	4" x 4" Inside corners
_____	_____	Outside corners

9" WALLS

How to find regulars and fractions needed for a "run".

1. Subtract sum of corner fractions from overall length of run.
2. Divide result by 2' to obtain number of regulars required. Remainder is fraction needed in wall. This gives you requirements for one side only.
3. Obviously, you must double these figures to obtain the requirements for both sides.

EXAMPLE:

What combination of forms are required for a 9" wall, 61' 2" long? Subtracting sum of corner fractions, 13" + 13" = 26" or 2' 2" from 61' 2" equals 59' 0". Dividing 59' 0" by 2 equals 29 regulars and a remainder of 1 ft. Doubling gives a total of 58 regulars and 2 - 12" fractions.

58 regulars	= 58' 0"
4 - 13" fractions	= 2' 2"
2 - 12" fractions	= 1' 0"
TOTAL	= 61' 2"

11

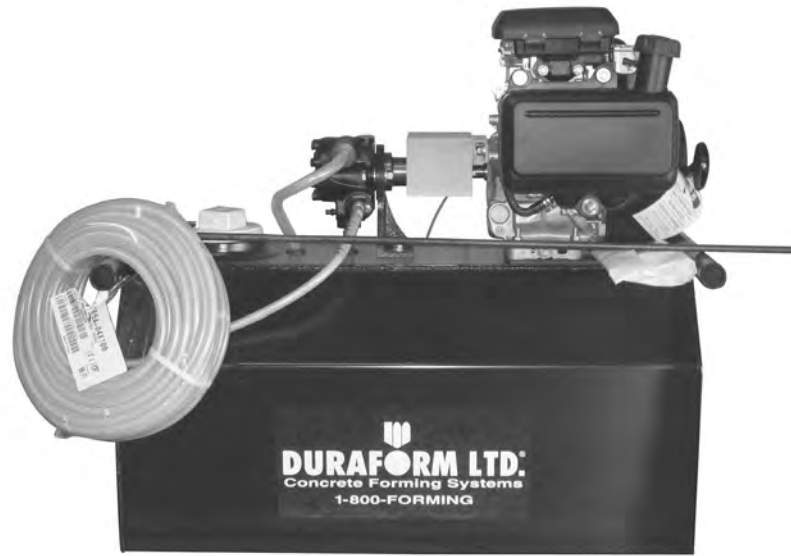

Form Sprayer

- Available in gas (GC160 4.6 Honda) or electric (12 Volt DC) motor.
- Available with 100' braided PVC hose.
- Quality investment in the added life of your DURAFORM® panels.
- Wand attachment allows you to disperse a uniform film of release agent without wasting time or valuable product.
- Drum sprayer also available.

Chutes

Available in:

- 12' Aluminum - Straight Mouth
- 14' Aluminum - Wide Mouth
- 16' Aluminum - Straight Mouth
- 18' Aluminum - Wide Mouth
- 20' Aluminum - Straight Mouth
- 12' Steel - Straight Mouth
- 16' Steel - Straight Mouth

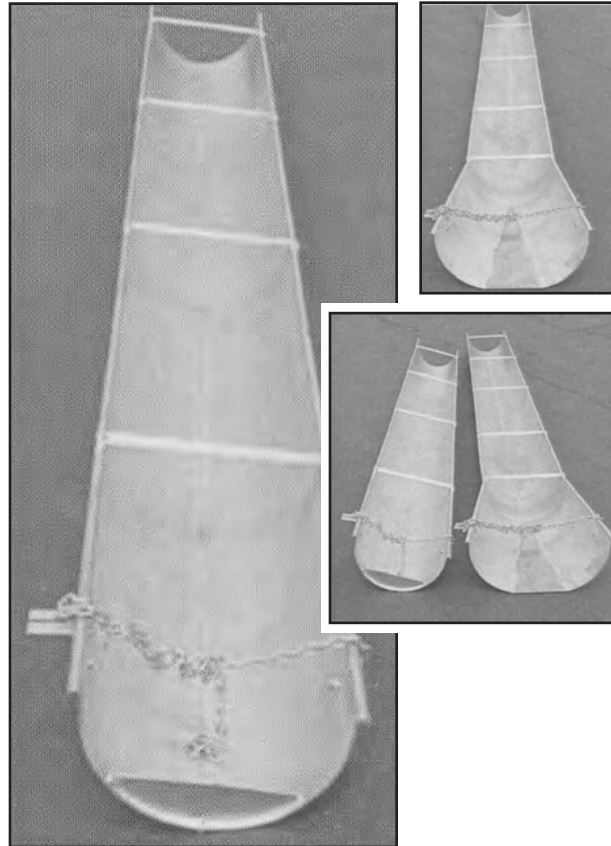
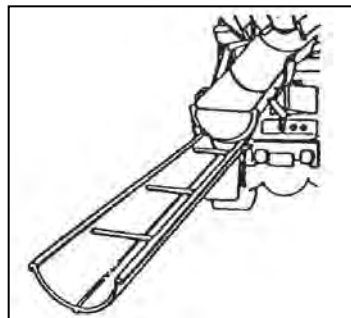

- NO RUST - abrasion-resistant aluminum means minimal maintenance. Just wash it and it is ready for the next pour!
- Rugged steel chain and lock bracket - allows for quick attachment to any chute.
- Cross bracing of welded bar aluminum.
- Durable, rugged construction allows you to place concrete where you need it.

Don't pull it.... Place it!

Strongback Clamps

- Available in screw and wedge configurations.
- Stack forms faster with "kneeing" eliminated.
- Placing vertical studs when stacking forms insures straight, true walls.
- Locks top and bottom forms together, providing a single unit to "plumb".

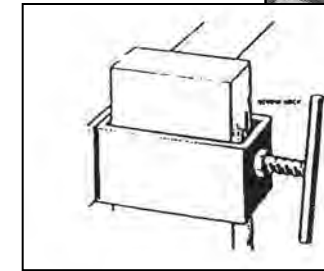

Strongback Walers

- Available in screw and wedge configurations.
- Offers additional horizontal and vertical alignment reducing deflection where it is most apt to occur. Improved finished walls are the result.

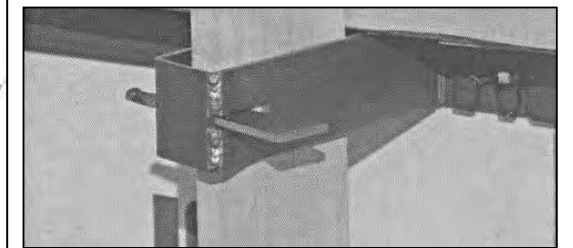
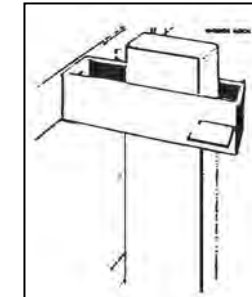

4" Waler with Wedge

- Straightens the wall using 2"x4"s with a wedge to hold forms tight and secure.
- Wedge can be locked in the up position, allowing for one man operation.
- If used on the 6-bar system, this bracket eliminates the need to align the top.

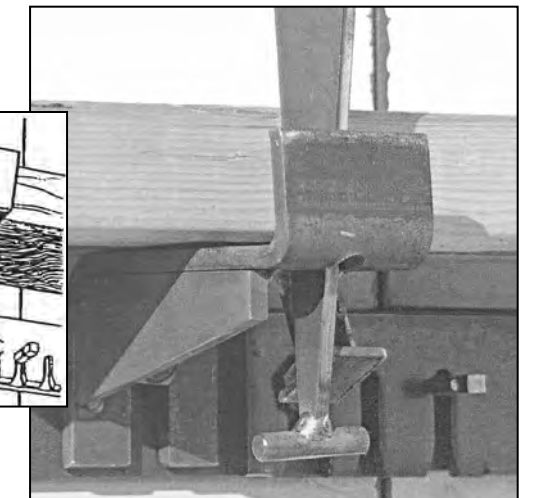
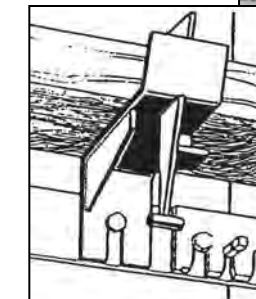

6" Waler Bracket

- Sturdy brackets hold dimensional lumber to the back of form panels.
- Attach to panels by locking on the accessory bolt.

Top Waler

- Constructed of 7 Gauge steel.
- The answer to straight and true walls - DURAFORM® Top Waler allows concrete to be poured to the top of the forms.
- Top Walers can be used to provide a stepped-in ledge to support top panels for stepped walls.
- Perfect solution for brick ledge problems - stop struggling and make your job easier!
- Placing Top Walers at alternating joints accurately aligns the top of the wall by locking with a wedge 2"x4" at the top outside of the forms.
- Using Top Walers and 2"x4"s allow you to strike off at the top of the form, leaving only a minute indentation in the finished wall.

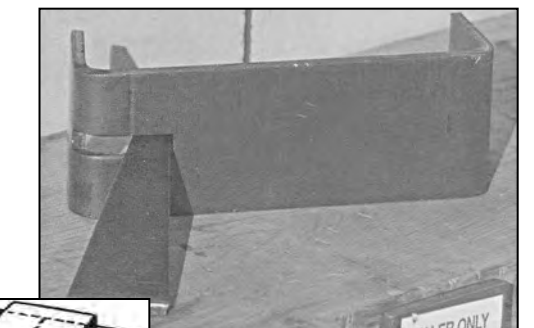
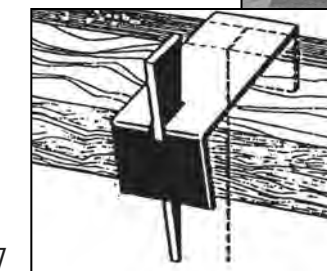

Heavy Duty Waler Brackets

- Straightens formed wall using standard 2" x 6" dimensional lumber.
- Available in 6" HD, 8" HD, 10" HD, and 12" HD sizes
- All HD Walers have additional stiff leg for heavy duty support.
- Attached to panels by locking the accessory bolt.

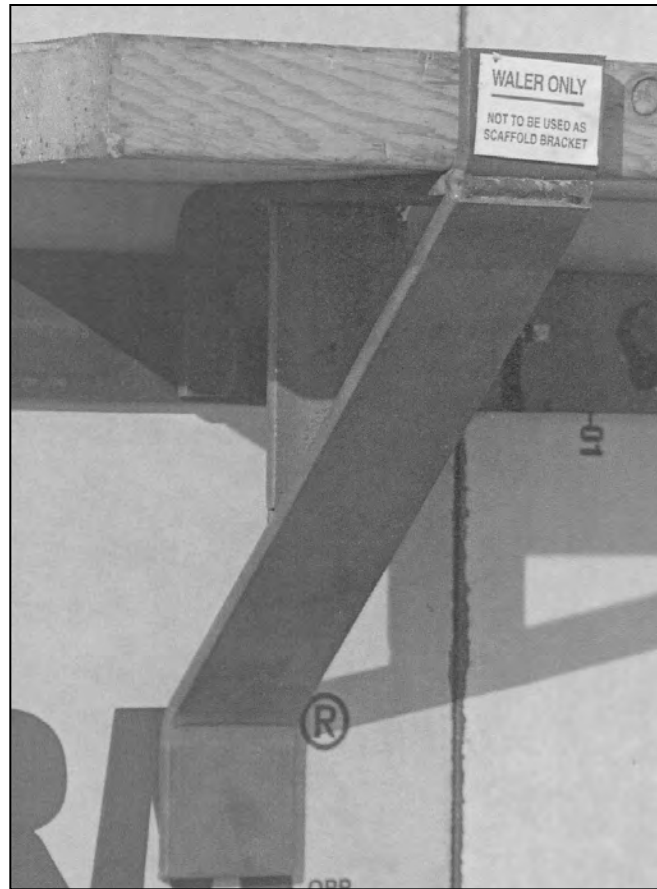

Break Off Tools

- Break off tie ends, releasing pressure on latch to start stripping forms.
- Available in Economy style.
- Lifetime Warranty.

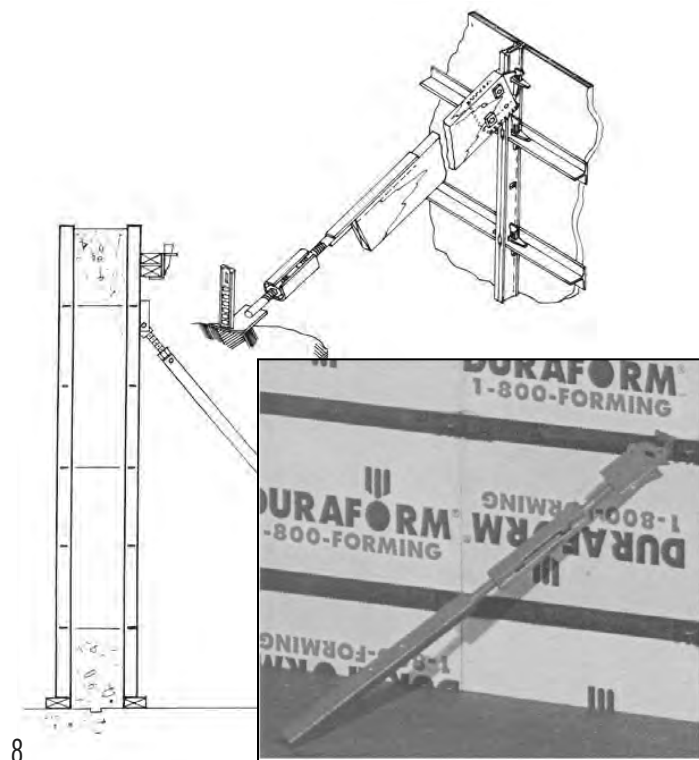
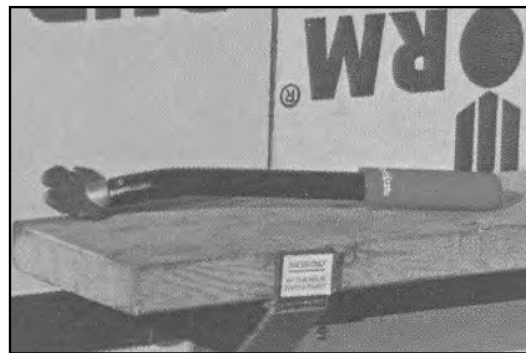
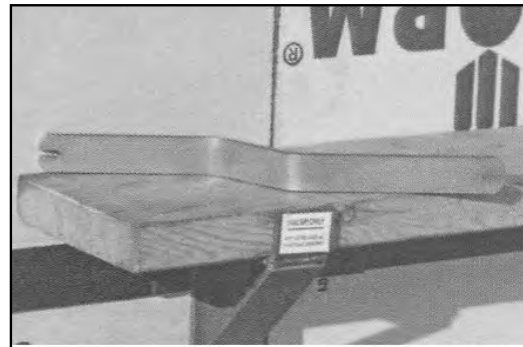

Turnbuckles

- Constructed of heavy steel.
- Adjusts alignment accurately and quickly.
- Rolled threads assure ease of operation, even when the forms are full.
- 6" Take Up.
- 10' Turnbuckle Wall Brace available - same DURAFORM® Turnbuckle assembly with steel piping attached to provide an all inclusive product.

8

Line Up Rail

- 12' heavy gauge steel.
- Flared "U" channel assures accurate wall alignment.
- Offers protection for the top of forms.
- The flared opening makes installation easy - even when forms are misaligned.

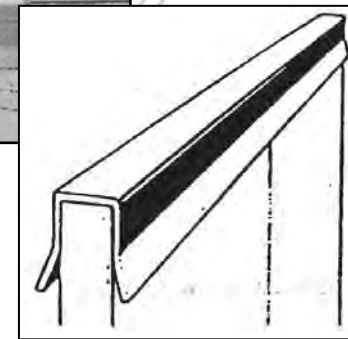

Spreader Clip

- Replaces the need for ties and loose clips when laying forms on their sides for 2' and 6' high walls.

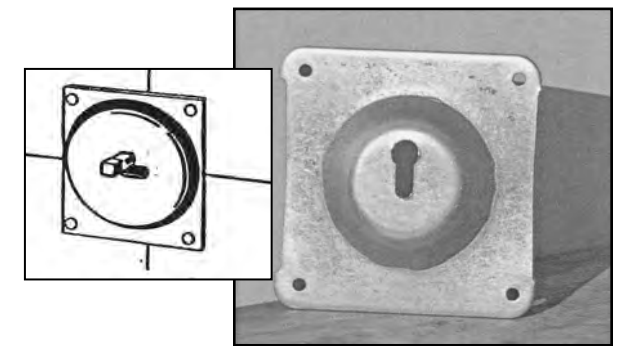
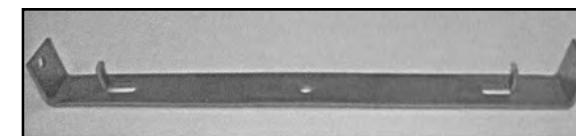

Stacking Plate

- Allows for placement of ties at the top of forms.
- Nails staked to panels prevent lift.
- Allows additional ties in the wall for supplemental strength.

Hex Bolts & Sleeve Nuts

- Used in combination to attach hardware or as field replacement hardware to high density overlaid plywood forms.

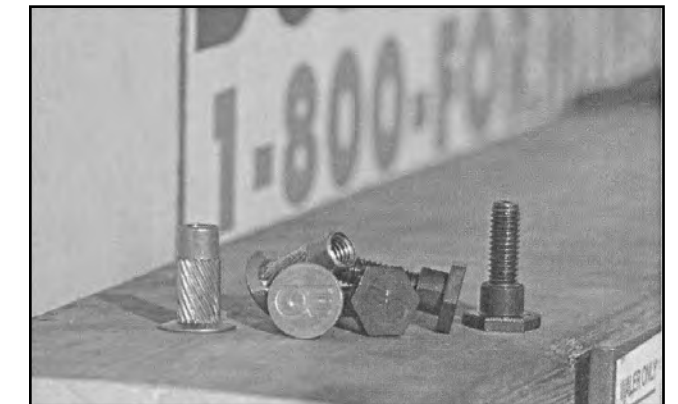

Superior 20" Scaffold Bracket

Superior 20" Scaffold Bracket

- Designed to fit properly on 4-bar, 5-bar, or 6-bar DURAFORM® or compatible systems.
- Built-in pockets to allow construction of a proper hand rail and toe board with a brace back to the form for rigidity.

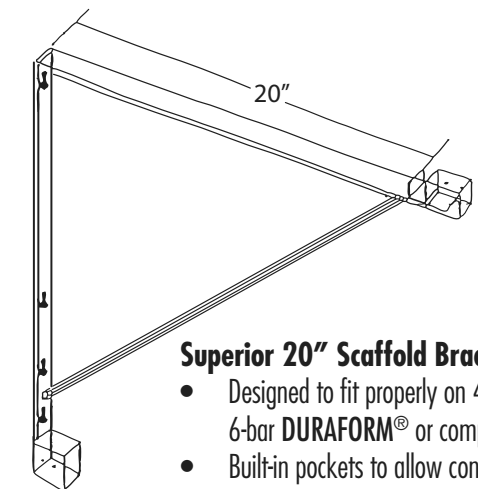

9